

Audi Vorsprung durch Technik



Audi India
Division of Volkswagen
Group Sales India Private Limited
Mumbai - India
www.audi.in
Valid from February, 2017

The models and equipment versions illustrated and described in this brochure and some of the services listed are not available in all countries. Some of the cars illustrated are equipped with optional features for which an extra charge is made. Details concerning the delivery specifications, appearance, performance, dimensions and weights, fuel consumption and running costs of the vehicle were correct to the best of our knowledge at the time of going to press. Deviations from the colours and shapes shown in the illustrations may occur. No liability is accepted for errors and printing errors. The right to introduce modifications is reserved. Not to be reproduced, including in part, without the written approval of AUDI AG.

Printed in India
Q3 DJ 1

U50A01MH2007/FT/CL68439

Audi Q3

Q3
Audi Q3





	Page	
Emotion		
	01	The Audi Q3 Experience
Technology		
	20	LED lights
	21	TDI
	23	S tronic
	25	quattro
	27	MMI – Multi Media Interface
	29	Lights
	31	Efficiency
Equipment		
	34	Interior
		Seats/seat covers
		Seating comfort
		Inlays
		Infotainment
		Interior equipment
	38	Exterior
		Lights/mirrors
		Wheels/tyres
		Paints
		Exterior equipment
	44	Technology/safety
	45	Audi Top Assist
	46	Audi Efficiency
Other		
	47	Dimensions
	48	Technical data

The new Audi Q3. Even more distinctive.

Here today, there tomorrow. You live on the move, you live in the now. After all, age is irreversible. That's why you want a car that can keep up with the frenetic pace of your lifestyle. Or shall we say: one that is so well prepared for you that all you have to do is get in. The Audi Q3 is this car. Powerful and agile, compact and yet spacious inside, efficient and expressive.

Start young. Live Big. The new Audi Q3.







With the same recognisable silhouette, the new Audi Q3 maintains its coupè-like appearance. With the addition of subtle design features like the 3D grille, chrome-plated tailpipe, LED headlights and panoramic sunroof it's a car that's now even more eye-catching. Inside, innovations like Audi drive select and electric lumbar support mean that the new Audi Q3 is not only beautiful to look at, it's also comfortable to drive.



The Audi Q3 Experience

Living dynamics. The athletic silhouette with the dynamic flat rear window signalises urban sportiness. The exciting interplay of light and shade modulates its sides. And the panoramic glass roof opens up the generous interior to the sky. Enjoy the view.







En route to driving enjoyment.

Get in, drive away, put new plans into practice. Always on the move.

In the Audi Q3, TDI engines will be driving you forward. All of them efficient and dynamic. From 110 kW to 135 kW and at top speeds of up to 219 km/h. The energy recuperation will actively save you fuel and reduce CO₂ emissions. During every trip. Go on.









En route to feeling comfortable.

Space for you. Space to develop. Expressive and individual: the interior of the Audi Q3. A horizontal line is drawn from the driver's side to the front-passenger door and seems to gently encompass the driver. The characteristic leather-covered steering wheel in the 4-spoke design is pleasant to grip, as is the leather gear lever knob.



The high-resolution colour MMI display is fitted in the centre of the dashboard where it is visible. You also have a Bluetooth interface and an Audi music interface to connect your iPod or MP3 player.







The seat upholstery underlines the high quality of the interior. Feel at home – there is plenty of legroom for the driver and the front passenger as well as in the back. And your luggage travels comfortably too: the generous loading space can be enlarged even further by folding the rear bench seat or the front-passenger seat down.



The Audi Q3 Experience

The ride is over. Or is it? Even when you have already reached your destination in the Audi Q3 you will want to choose a new one within minutes. Remain demanding. Remain en route. In the Audi Q3.



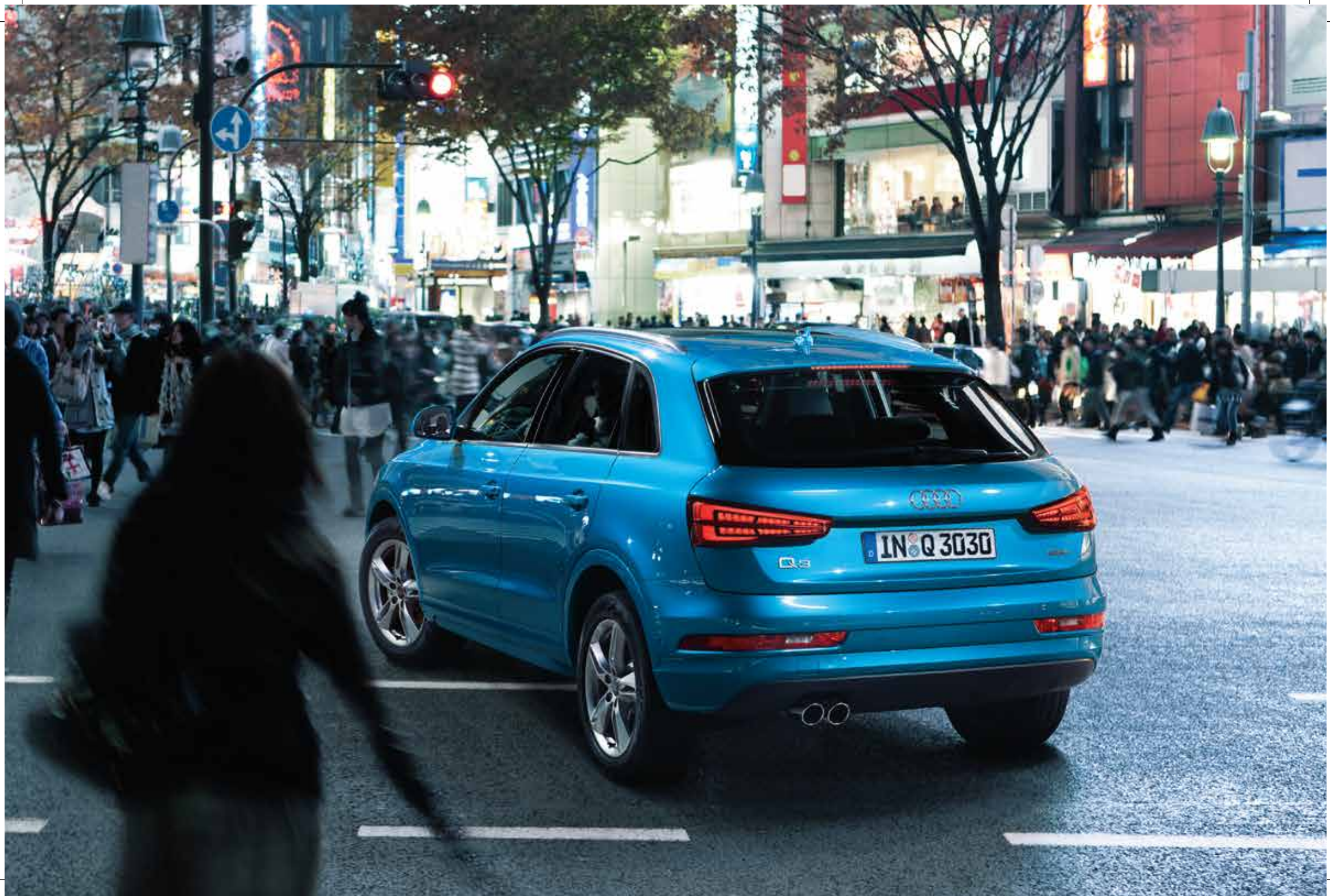





LED lights

Look good. See better.

The Audi Q3 is available with standard LED headlights. This innovative technology means that a continuous beam of bright light is emitted, lighting the road ahead with a colour close to daylight and providing an unprecedented clarity of vision.

What's more, the sleek and subtle design of Audi LED headlights make them the perfect addition to the new Audi Q3. And with dynamic LED indicators at the rear, the striking look is complete.

TDI: Start an evolution.
And keep repeating it.



A diesel on the podium: the Audi R18 TDI

Exhaust-gas turbocharger
with optimised adjustable turbine geometry

1,800 bar high-pressure injection system

Engine with reduced friction

Compensating shaft module

Pressure-regulated oil pump



2.0L TDI engine

One in every two Audi cars sold today is a diesel. What sounds perfectly normal now was the cause for huge excitement 20 years ago, when Audi revolutionised the market with the first 2.5 TDI engine. Since then, developments such as common-rail technology have made TDI even more efficient. Injectors ensure the fuel is finely and precisely distributed. Consequently, since the first TDI, the engines have become more economical, whilst specific output has increased. So it was only logical that a diesel car should then enter the world of motorsport. And successfully too: in 2006, Audi was the first car maker to win the Le Mans 24 Hours with a diesel-powered race car, the Audi R10 TDI – and then went on to repeat this victory several times over, most recently in 2011.

The combination of turbocharging and direct injection also ensures superior driving dynamics and efficiency for the 2.0 litre diesel unit. In the Audi Q3, a new generation of the four-cylinder engine is used, based on the most produced diesel engine in the world. It offers further optimized acoustics, greater refinement and more spontaneous power delivery. The engine is available with two output ratings: 110 kW and 135 kW.

- ▶ High torque of 340 Nm (for 110 kW) and 380 Nm (for 135 kW) over a wide speed range
- ▶ Majestic, effortless pulling power even from standstill



1.4L TFSI engine

- ▶ Modern common rail technology and injection pressure of up to 1,800 bar provide for a high level of refinement and precise fuel metering
- ▶ 110 kW unit combined with precision 7-speed S tronic dual-clutch transmission and front-wheel drive
- ▶ New in the Audi Q3: highly efficient 4-cylinder inline petrol engine combining turbocharging with direct petrol injection - TFSI
- ▶ 110kW unit combined with precision 6-speed S tronic dual clutch transmission and front wheel drive.

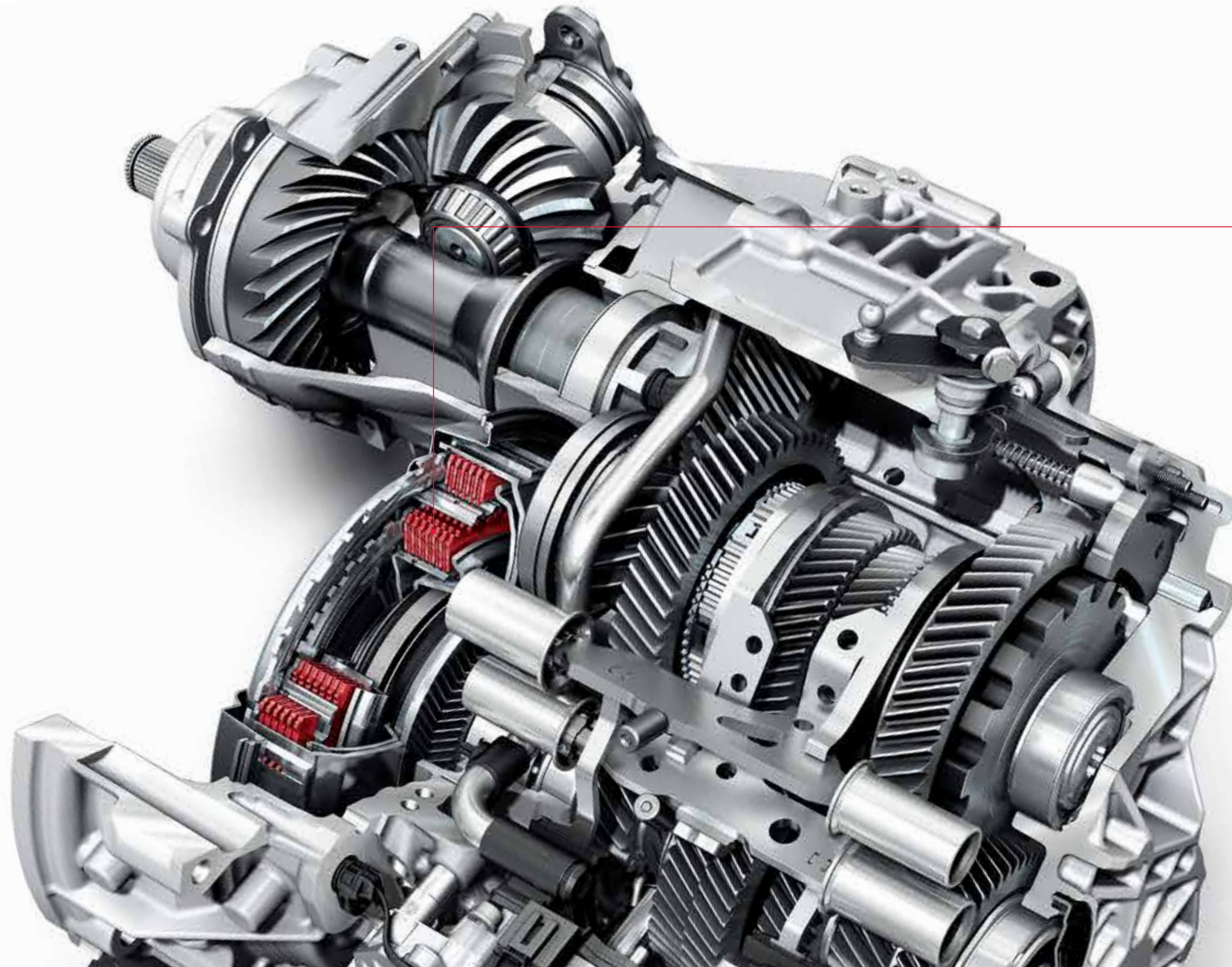

What is the benefit of two clutches?

A double saving: time and energy.

The 7-speed dual-clutch transmission S tronic enables rapid gear shifting with hardly any perceptible break in propulsive power and is efficient at the same time.

Long ago, in 1985, Walter Röhrl tested this technology in the Sport quattro S1 – and was suitably impressed. Audi drivers share their enthusiasm to this day, because the modern S tronic changes gear in a flash. To do this, two multi-plate clutches serve the different gears. One clutch transfers the torque via a drive shaft to the gearwheels of the odd-numbered gears.

The second clutch serves the even-numbered gears via a hollow shaft. Both parts of the transmission are permanently active, but only one of them is actually connected to the engine via a closed clutch. For example, when the driver accelerates in third gear, the second part of the transmission is already engaged in fourth gear. The gear change happens very quickly through the change of clutches – the first clutch opens while the second one closes. The gear change only lasts a few hundredths of a second and is completed with virtually no interruption in the power flow. It runs so smoothly and comfortably

that the driver barely notices it. It doesn't matter whether the driver chooses the fully automatic modes with the program D (Drive) or S (Sport) or changes gear manually with the selector lever or the optional shift paddles on the steering wheel – the gear change feels precise and extremely sporty. Even with all of this dynamic technology, the S tronic still remains efficient. Due to its high level of efficiency, both fuel consumption and emissions can be reduced. While the TDI engine comes with 7 speed S tronic transmission, the TFSI comes with 6 speed S tronic transmission.

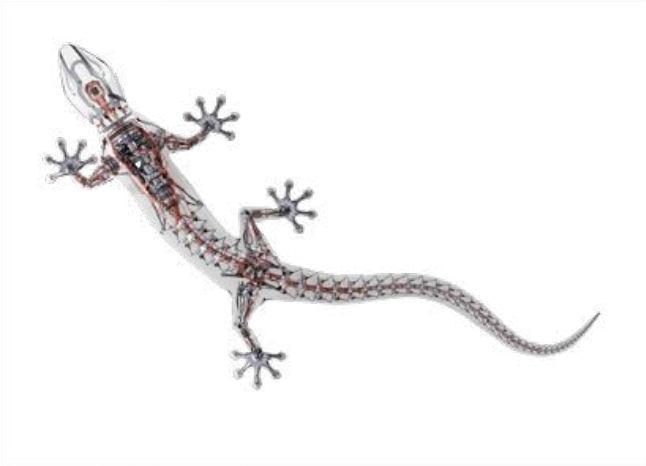

With quattro, we have created one of the best all-wheel drive systems in the world.

Of course, that was not good enough for us.

quattro is a permanent all-wheel drive system. If the wheels on one axle of the vehicle lose grip on the road and threaten to spin, the wheel-selective torque distribution transfers the power through the transfer gear box and the Haldex

clutch to the axle or individual wheel with a better grip. The benefit is better traction and thus improved acceleration as well as more safety thanks to more balanced lateral guide forces.

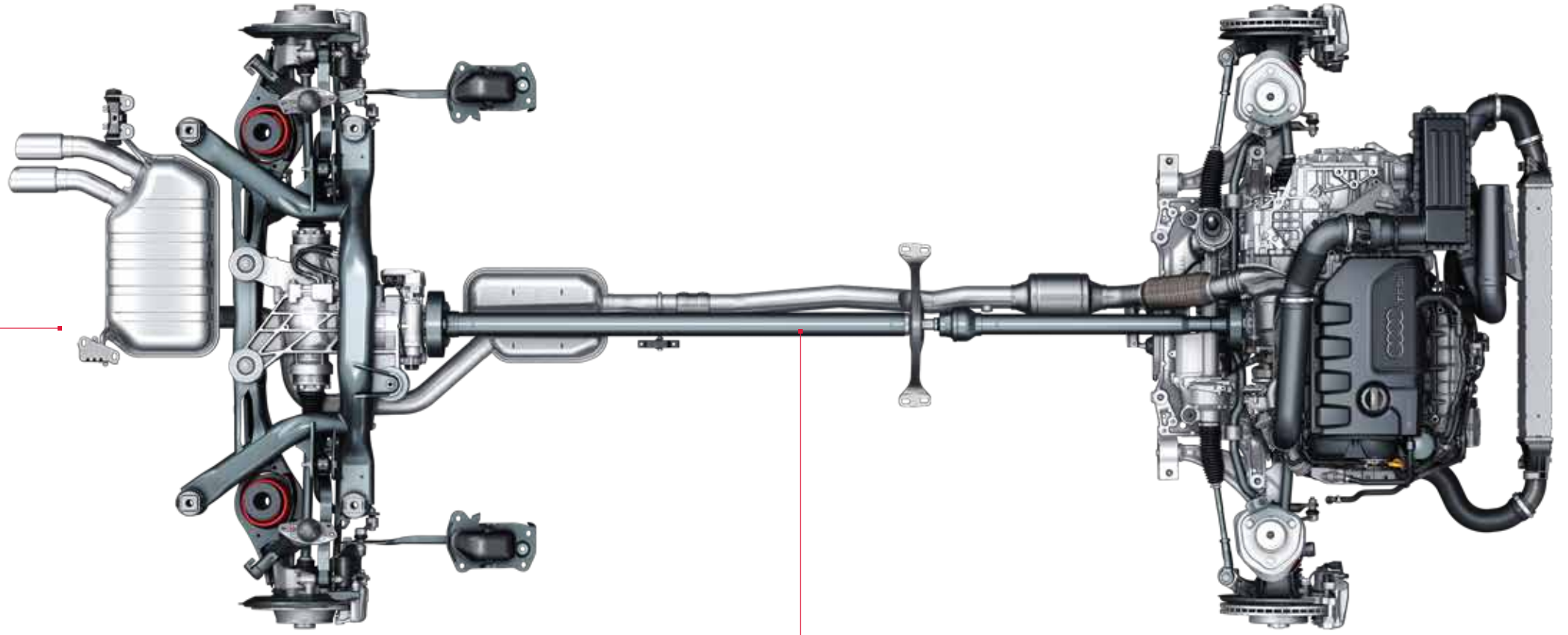

The quattro drivetrain

Technology is advancing at an ever faster pace and choosing the right technology for your car is an important decision.



MMI Navigation Plus*

With HDD-based MMI Navigation, you'll have access to 3D map view and 3D point-of-interest display. It means you'll be guided to your destination with greater ease. And, because destinations can be entered with speech recognition, your attention remains firmly on the road.



Colour Driver's Information System (DIS)*

A high-resolution 7-inch colour display, located in the instrument cluster, provides key information from the driver assistance systems.



Audi parking system advanced with rear reversing camera*

Aids parking by acoustically and visually indicating distances to obstacles with guiding lines. Measured by sensors and a rear reversing camera.

*Optional





Daytime running lights



Dipped beam



Indicator

Seeing and being seen is a safety issue.

The standard LED headlights emit beams of bright light with a colour close to daylight and an unprecedented clarity of vision.

The LED headlights also come with LED dynamic indicators in the rear. These indicators have LEDs which light up at intervals of one tenth of a second. This enables other drivers to exactly determine which direction the car is turning, even from far away. Talk about safety.







It is the equipment that turns an Audi into your Audi.

Upholstery



Leather/Leatherette, black



Leather/Leatherette, Pistachio beige

Seats/seating comfort

**Centre armrest, front**

can be adjusted lengthways, adjustable angle, with fold-open storage compartment and one 12 V socket in the rear centre console

4-way lumbar support

electric, for driver and front-passenger seats, with horizontal and vertical adjustment

Head restraints

for all 5 seats, height manually adjustable

Rear centre armrest with cup holders.

**Front seats, electrically adjustable**

electric seat height and front/back adjustment, seat and backrest angle adjustment

Folding rear seat backrest

can be split and folded 40:60 or fully

Inlays



Walnut balsamic, brown¹



Inlays in Aluminium Tangent Bronze/Silver²

¹ Available on 2.0 TDI (110kW) and 1.4 TDI (110kW).

² Available on 2.0 TDIq (135kW).

*Optional

Driver information system

with a white 3.5-inch TFT monochrome display located directly in the driver's field of vision. Displays the following information: radio frequency and/or name of station or title as well as further contents of the infotainment system such as navigation,* phone menu (if fitted) or radio-controlled clock display of onboard computer with long and short-term memory, outside temperature display, digital speedometer and door/tailgate open warning indicator. The integrated efficiency program provides assistance in the form of consumption data overviews, a display of additional loads, gearshift display and fuel-saving tips for adopting a more economical driving style

Telephone and communication

Bluetooth interface

Bluetooth-compatible mobile phones can be connected to the vehicle via the interface. Hands-free calls in the vehicle possible via microphone. Including Bluetooth audio streaming (depending on mobile phone compatibility)

Radio and TV systems

Audi sound system*

10 speakers including centre speaker in the dashboard and subwoofer in the spare wheel well, total output 180 watts, 6-channel amplifier

MMI radio

with single-CD player and SDHC memory card reader (both MP3, WMA and AAC-compatible) and AUX-IN connection. Offset 6.5-inch TFT colour display, MMI operating concept, dynamic station list (for VHF), 50-station memory, VHF, MW and LW reception. Speed-sensitive volume adjustment (GALA) and phase diversity, TP memo function whilst driving and car menu, 8 passive loudspeakers in the front and rear, total output 80 watts

MMI Navigation Plus*

HDD-based MMI Satellite Navigation plus includes the following: navigation data saved on hard disk drive, high-resolution 7" colour display screen with high-quality map view, map with topographical shading and many points-of-interest and city models shown in 3D. A choice of 3 alternative routes can be selected where possible.

- Includes a rotary button with integrated joystick function for searching in the map
- Route information is displayed on a split screen
- Detailed intersection map and lane recommendations
- Dynamic route guidance
- Navigation address can be input using the voice control system
- Route arrow instructions displayed in colour in the Driver's Information System

Also includes a hard disk drive jukebox function which can be used to store up to 20 GB of music (MP3, WMA, AAC and MPEG4 compatible) and a DVD drive for playing music and video DVDs (when the car is stationary).

The MMI Navigation Plus can be operated via the MMI controls, multi-function steering wheel or voice control system

Climate control



Deluxe automatic air conditioning

with sunlight-dependent control, separate pre-selectable control for driver and front passenger; electronically regulates the air temperature, air flow rate and air distribution; automatic recirculation mode by means of air quality sensor, combined filter, separate defroster button for rapid defrosting of the windscreen and side windows, key recognition, includes a light/rain/humidity sensor, climate control of the rear by means of air vents in the rear centre console, includes ventilated glove compartment

* Optional

Steering wheels/gear levers/controls

Leather-covered multifunction steering wheel in 4-spoke design; with paddle shifters*
leather-covered steering wheel in 4-spoke design; with multifunction buttons for operating the Audi radio, voice control system and fitting for mobile phone

Audi drive select

changes vehicle characteristics by, e.g. adapting power steering assistance, accelerator and gearshift characteristics. Available modes: comfort, auto and dynamic



Luggage securing and storage systems



Storage compartments

in front side trims, includes bottle holder (1.5 l) as well as storage compartment in the front centre console and in the rear door trims

Glove compartment

on the front-passenger side, illuminated

Drinks holders

in the front centre console

Further interior equipment

Floor mats, front

in velour, coordinated with the carpet colour

Floor mats, rear

in velour, coordinated with the carpet colour

Window controls

electric for front and rear, with safety system to limit maximum closing force, convenience opening/closing via central locking, one-touch opening/closing function

Centre console

raised, with storage compartment which can also be used as drinks holders when cover is open

12 V socket

in the front centre console

Assistance systems

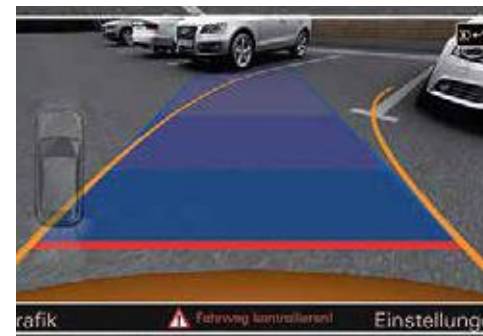

Parking aid plus with rear view camera*

acoustic and visual parking system for the front and rear with display of symbols on the screen to indicate distance from an obstacle; measurement is by ultrasonic sensors concealed in the bumpers

Parking aid, rear

makes parking easier by indicating acoustically how far away the vehicle is from an obstacle; measurement is by ultrasonic sensors concealed in the bumpers

Cruise control

at speeds of 30 km/h and above, the system keeps the set speed constant, provided that engine power and engine braking effect permit it; operated via separate steering column stalk, set speed displayed in driver information system

Hill-descent control

speed control by means of brake intervention and engine drag torque, whilst constantly maintaining the speed depending on the surface. The driver just has to steer, but does not have to accelerate or brake

*Optional

Lights

**LED Headlights**

LED headlights provides lower energy consumption and enhanced contrast with colour similar to daylight for increased safety and good recognition. Includes all weather light function to reduce the risk of drivers being dazzled when visibility is poor

**LED rear lights with dynamic turn indicators**

in an innovative lighting design; brake lights, tail lights and indicators in energy-saving and long-lasting LED technology for faster activation and thus earlier recognition by the driver behind; 2 rear fog lights; 3rd high-mounted brake light in the rear window, reversing lights in white.

Lights

**LED interior lighting package**

anti-glare lighting for the passenger compartment in energy-saving and long-lasting LED technology. Comprising of an ambient reflected light in the roof module and entrance lighting as well as illuminated make-up mirror, storage compartment in the centre console and drinks holders. Lighting for door pockets, footwells and inside door handles, reflected lighting for centre console and door inner panels to help occupants find their way around, active door reflectors

Light/rain sensor

for controlling the automatic driving light, the coming home/leaving home function and the automatic windscreen wiper function, includes windscreen with grey coloured strip (along the top edge), includes windscreen with acoustic glazing (for improved windscreen insulation and a reduction of outside noise)

Mirrors

Exterior mirrors electrically adjustable, heated, electrically folding and auto dimming on driver's side with integrated LED indicators

**Interior mirror**

with automatic anti-glare action

Make-up mirror

in driver and passenger's sun visor

Roof systems

**Panoramic glass roof**

in 2 sections, electrical activation to raise and open the front glass section, tinted glass insert; including an electrically operated sun blind for the front and rear passengers, convenient closing from the outside via the central locking system or radio-operated remote control; ensures a comfortable interior that is flooded with light, improved interior climate by means of efficient ventilation



Cast aluminium alloy wheels in 5V spoke design
size 7J x 17 with 235/55 R17 tyres

Anti-theft wheel bolts
can only be loosened using adapter provided

Space-saving, spare wheel
permissible top speed 80 km/h

Vehicle tool kit
in the luggage compartment

Jack
in the luggage compartment



| Solid Colours



Cortina White

| Metallic Colours



Floret Silver



Mythos Black

| Pearl Effect



Misano Red



Hainan Blue

Exterior

Lights/mirrors Wheels/tyres Paints Exterior equipment

Closing systems

Central locking system

with radio-operated remote control incorporated into the vehicle key, variable code and autolock function; with one touch of the button the system opens and locks doors, tailgate and tank flap

Electronic immobiliser

incorporated in the engine control unit, automatic activation by vehicle key

Glazing

Heat-insulating glass

green-tinted, windscreen made of laminated glass

Rear window

heated, with timer switch; additional heating of the lower end position of the rear window wiper

Windscreen cleaning system

4-speed adjustable intermittent wipe, flick-wipe function, automatic wash-wipe, with reversing wiper system and park setting to increase the service life of the wiper blades; when reverse gear is selected the rear window wiper is activated for the duration of the reversing manoeuvre (if front wipers are switched on)

Sun visors

can be folded and swivelled, on the driver and front passenger sides with covered make-up mirror

Further exterior equipment

High-gloss package

roof frame and window slot trim in anodised aluminium, exterior B and C-pillar trim in high-gloss black

Roof rails

one-piece, no joints, stable and aerodynamic in anodised aluminium

Roof edge spoiler

Exhaust tailpipes

single-branch design with 2 tailpipes on the left. With chromed trim

Suspensions/brakes

Dynamic suspension

McPherson spring strut type axle at front with lower wishbones, aluminium subframe, with 4-link rear axle with separate spring/damper arrangement, subframe

Electromechanical parking brake

includes parking brake function when stationary

Auto release function

drive-off assistance function by means of automatic release when driving away and emergency braking function whilst driving by means of action on all 4 wheels

Technology/Safety



Child-proof locks

mechanical for the rear doors and electric for the rear window controls

Instrument cluster

with adjustable lighting, electronic speedometer with odometer and trip odometer, rev counter, digital clock, coolant temperature display and fuel gauge

Seat belts

3-point inertia-reel seat belts for all seats (with belt force limiters, belt tensioners and belt height adjustment for the front seats only)

Seat belt reminder

for all seats; an acoustic and visual warning signal reminds occupants in the front to fasten their seat belts, a visual warning signal indicates when seat belts have been undone in the rear



Full-size airbags

for driver and front passenger, side airbags incorporated into the front seat backrests; the head airbag system protects the front and outer-seat rear occupants in the event of a side impact; unfolds like a protective cushion over the side windows

Side-on collision protection

consisting of bending-resistant door impact beams and reinforced body side structure, particularly in the B-pillars and sills

Technology/Safety

Integrated head restraint system

in the event of a rear-end collision the design of the seat restrains the upper torso and supports the head; this increases safety and reduces the danger of whiplash

Steering column

manually adjustable for height and reach

First-aid kit with warning triangle

Anti-lock Braking System (ABS)

with electronic brake force distribution EBD and hydraulic brake assist

Traction control (ASR)

reduces spinning of the drive wheels by reducing the engine output and delivers more traction and stability on the road surface

Electronic Differential Lock (EDL)

on surfaces with varying levels of grip, this start-off assistant automatically brakes the drive wheels on the surface that is too slippery, thereby ensuring smooth, powerful progress

Electronic Stabilisation Control (ESC)

networks ABS, ASR and EDL with its own sensors and compares the driving data with reference data; provides better stability by targeted braking of individual wheels and intervention in the engine management system, passive rollover, brake disc wiping function

Wheel-selective torque distribution

incorporated into ESP; modifies driving force by means of targeted braking actions depending on the driving situation, when cornering the torque distribution ensures smoother and more precise handling with no understeering; improved traction and dynamic performance when cornering

Electromechanical power steering

maintenance-free rack & pinion steering with speed-dependent servo assistance; precise steering feel at high speeds, excellent assistance when parking; active countersteering providing steering assistance to the driver for enhanced vehicle stability

S tronic

the dual-clutch transmission facilitates rapid gear shifting without a perceptible interruption in power flow; can be operated via the optional shift paddles behind the steering wheel, the gear lever knob or in automatic mode

quattro

permanent all-wheel drive with dynamic torque distribution, electronically controlled Haldex clutch and Electronic Differential Lock (EDL) via braking intervention on all driven wheels (available on 2.0 TDIq (135kW).

Audi Top Assist

By your side, no matter where you are across India.

Our philosophy of Vorsprung durch Technik goes beyond advancement through technology. It is the pursuit of perfection. It is a philosophy where luxury transcends cars. That's why at Audi we have introduced the Audi Top Assist program where you can enjoy uninterrupted driving pleasure. With the Emergency Road Side Assistance services across the country, our team of experts are at your service, 24 hours a day, 7 days a week.

EMERGENCY ROAD SIDE ASSISTANCE SERVICES

To avail of the Emergency Road Side Assistance all you have to do is call one of our dedicated toll-free numbers and we will immediately dispatch a motorcycle rider wherever you are. In case your Audi needs further attention, we will dispatch our specially designed towing vehicle to shift it to the nearest service centre. In fact, in special cases, we may also arrange for alternate travel and accommodation facilities*.

THE AUDI ADVANTAGE

- Two dedicated toll-free numbers
- 24 hours, 7 days a week, 365 days a year service
- 95% coverage of India with over 600 service providers
- Dispatch of a motorcycle rider, a taxi and a towing truck at site
- Taxi of upper-class standards free of cost for up to 48 hours
- Travel & accommodation facilities in case of immobilisation for more than 24 hours
- On-site repairs, delivery of fuel and spare keys
- Custody, transportation, storage and safekeeping of vehicle
- Transport of vehicle to destination or habitual residence
- Assistance available during standard warranty period of the car

1-800-103-6800

Accessible from any network
(except MTNL Mumbai and Delhi).

1-800-209-6800

Accessible from any network
(except Jammu Kashmir and North East).

With Audi Top Assist, you are assured of a world-class luxurious experience, wherever you are. Speak to an Audi Dealer for more information.

*Conditions apply

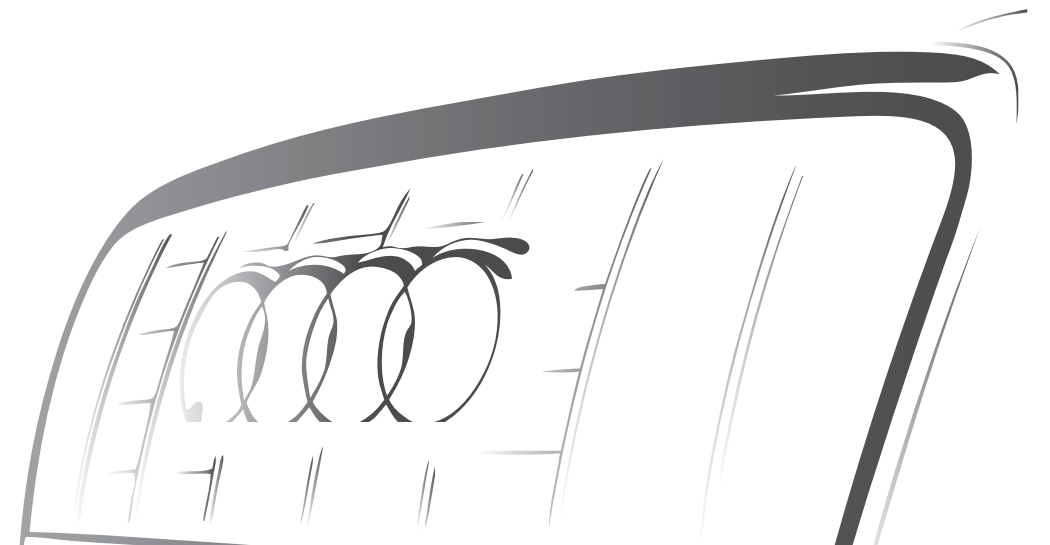

Efficiency: standard in every Audi.



Vorsprung durch Technik is the claim to which the Audi brand is committed. It includes giving careful consideration time and again to each droplet of fuel. For many years, Audi has been translating this claim into tangible reality on all its models – and as a developer of numerous innovations, is having a lasting influence on

efficiency standards in automotive engineering. Whether with the TDI, FSI, and TFSI engine concepts, with transmission technologies or with the Audi Space Frame (ASF). To achieve on-going improvements in energy consumption, a number of intelligent efficiency measures – specially tailored to each vehicle – are combined.

Efficiency with a methodical approach – individual and standard. A commitment which is already leading to convincing results. Audi already has many models in its current range that emit less than 140 g CO₂/km. An effective way of reducing emissions. And just as impressive as the fact that a large proportion of Audi vehicles already meet

the strict EU 5 emissions standard. All this demonstrates the know-how of Audi – and is what drives us on every day to harmonise sportiness and efficiency in the future.

Audi Q3

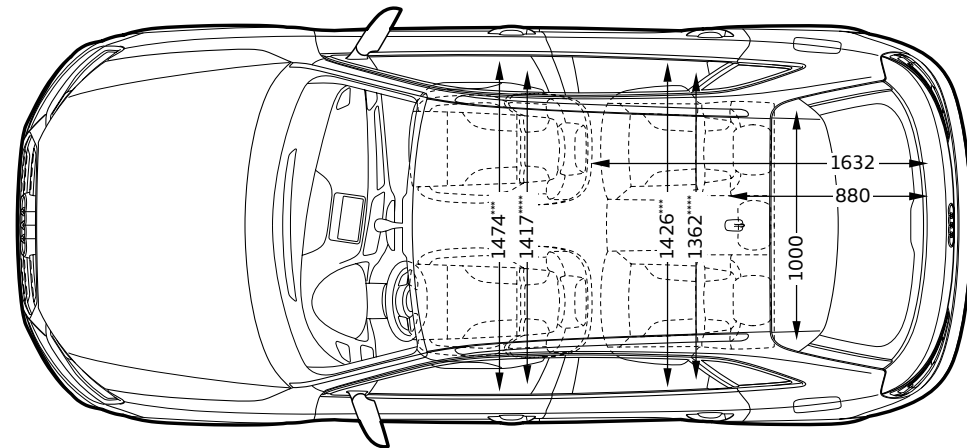
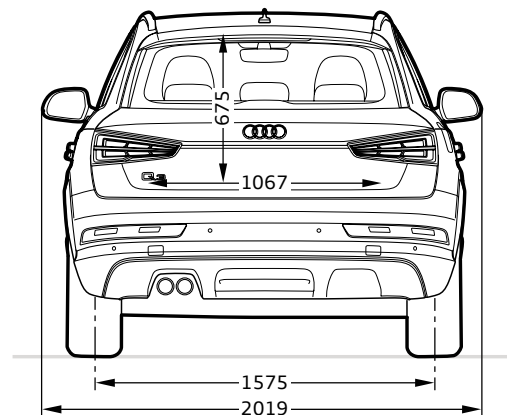
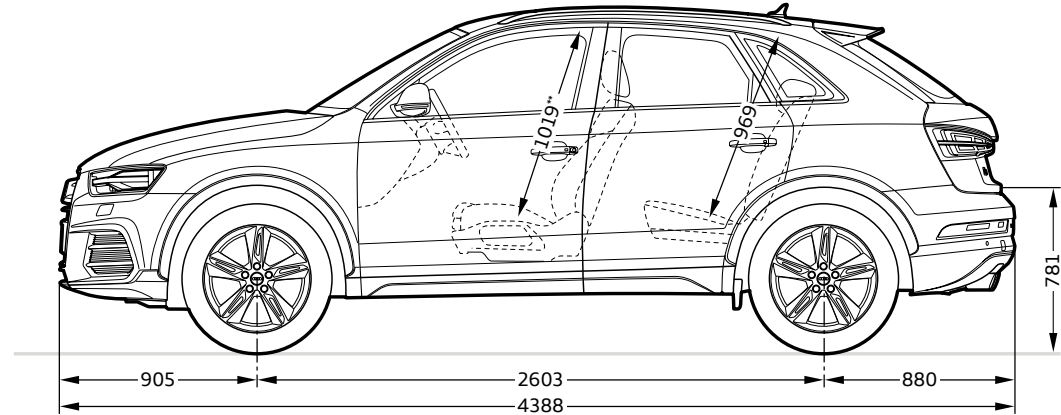
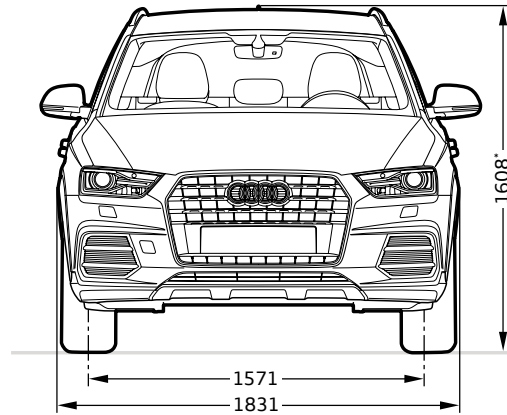
**Dimensions in millimetres.**

Dimensions were measured with vehicle at unladen weight.

Luggage compartment volume in l: 460/1,365 (measured by the VDA method using 200 x 100 x 50 mm blocks; second value: is with the rear seat folded down and the vehicle loaded up to roof height). Turning circle approx. 11.8 m.

* Without roof aerial the vehicle height is reduced by 18 mm ** Maximum headroom

*** Elbow room width **** Shoulder room width

Model	Audi Q3 35 TDI quattro (135 kW)	Audi Q3 30 TDI (110 kW)	Audi Q3 30 TFSI (110 kW)
Engine type	4-cylinder in-line diesel engine with common rail injection system and exhaust-gas turbocharging	4-cylinder in-line diesel engine with common rail injection system and exhaust-gas turbocharging	4-cylinder in-line petrol engine with direct fuel injection, turbocharging and Audi valvelift system
Displacement in cc (valves per cylinder)	1968 (4)	1968 (4)	1395 (4)
Max. output ¹ in kW at rpm	135@3500-4000	110@3500-4000	110@5000-6000
Max. torque in Nm at rpm	380@1750-3000	340@1750-2750	250@1500-3500
Power transmission/wheels			
Type of drive	quattro permanent all-wheel drive	Front-wheel drive	Front-wheel drive
Transmission	7-speed S tronic	7-speed S tronic	6-speed S tronic
Wheels	Cast aluminium wheels 7J x 17	Cast aluminium wheels 7J x 17	Cast aluminium wheels 7J x 17
Tyres	235/55 R17	235/55 R17	235/55 R17
Weights/capacities			
Kerb weight in kg	1630	1650	1565
Gross vehicle weight in kg	2225	2115	2005
Fuel tank capacity, approx. in l	64	64	64
Performance/consumption²			
Top speed in km/h	219	204	204
Acceleration 0–100 km/h in s	7.9	9.3	8.9
Fuel grade	Diesel	Diesel	Petrol
Fuel consumption ³ in km/l	15.17	18.51	16.90
Emission standard	EU4	EU4	EU4

Explanatory notes

¹ The figure given was calculated using the specified measuring procedure (current version of Directive 80/1269/EEC).

² A vehicle's fuel consumption and CO₂ emissions do not just depend on how efficiently the vehicle uses the fuel, but are also influenced by driving behaviour and other non-technical factors. CO₂ is the greenhouse gas primarily responsible for global warming.

³ The values stated were calculated using specified measuring procedures as per Bharat Stage IV by ARAI.

Important note

Inspections are due as shown by the service display.

The information contained herein is accurate as of the date of publication. Illustrations may show equipment which is optional and not part of standard specifications. Models, combinations and configurations, colours and equipment illustrated may differ from products supplied in the Indian market. Audi may alter or change designs, specifications, and combinations and configurations. Please contact an authorised Audi dealer for more exact information.

Some of the images & features shown are relevant to markets overseas and are shown for illustrative purpose only. These images may not be similar to right hand driven vehicles sold in India. Availability of specific models & variants are subject to release in India.

